

KLEZZMATES

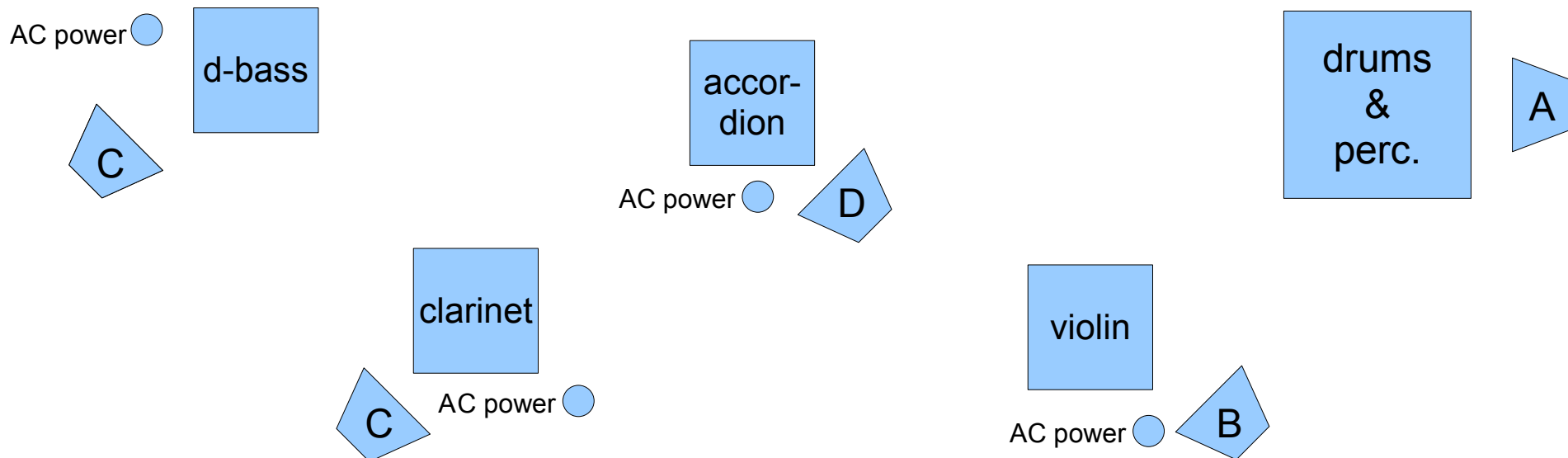

AUDIENCE

1.	kick	d-112, d-12
2.	snare	sm57, e-903
3.	tom1	e-604
4.	tom2	e-604
5.	tom3	e-604
6.	floor-tom	e-604
7.	hi-hat	sm57
8.	darabuka	sm57
9.-10.	overheads L/R	condenser
11.	percussions	condenser
12.-13.	pads L/R	2 x di-box
14.	d-bass	XLR direct output on amp's back
15.-16.	accordion L/R	2 x di-box
17.-18.	clarinet L/R	2 x di-box
19.	violin L/R	2 x XLR direct output or 2 x di-box
20	violin	condenser
21.	speech-microphone	unrestricted but with switch, placed on accordionist mixer, without stand.

comp, no gate
comp, no gate
comp, no gate
comp, no gate
comp, no gate
comp, no gate

mic. placed under darabuka, reverb
reverb
hall-reverb

reverb .80Hz HPF
NO PHANTOM POWER! on these channels.
reverb

4 monitor mixes
on 5 speakers,
all mixes WITH NOTCH
on 280Hz!